

LEGEND			
PROJECT BOUNDARY	--- --	PUE (TYP)	---
VILLAGE LOT LINE	---	VILLAGE BOUNDARY	---
RIGHT-OF-WAY	---	TOP BACK OF CURB	---
STREET CENTERLINE	---	SIDEWALK	---
PROPOSED LOTS	---	LIP OF CURB	---
SEWER MAIN	---	SEWER MANHOLE	●
WATER MAIN	---	DRAINAGE MAIN	---
DRAINAGE MANHOLE	●	DRAINAGE MANHOLE	●
DRAIN INLET	---	DRAIN INLET	---
GATE VALVE	---	GATE VALVE	---
FIRE HYDRANT	---	FIRE HYDRANT	---

TENTATIVE SUBDIVISION MAP

AMORUSO RANCH

PHASE 1 - SUBPHASE A1

CITY OF ROSEVILLE, CALIFORNIA
FEBRUARY 14, 2022

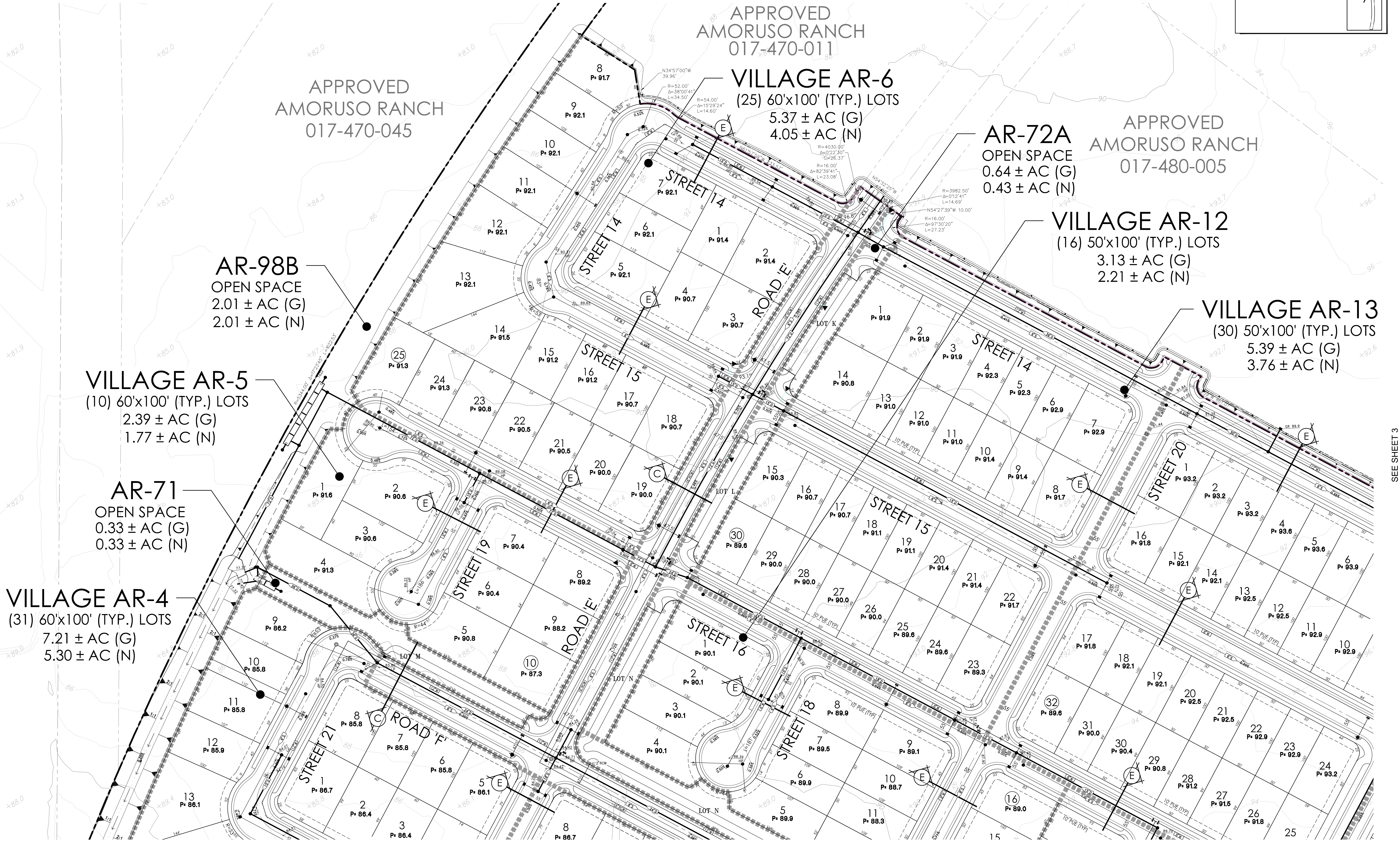
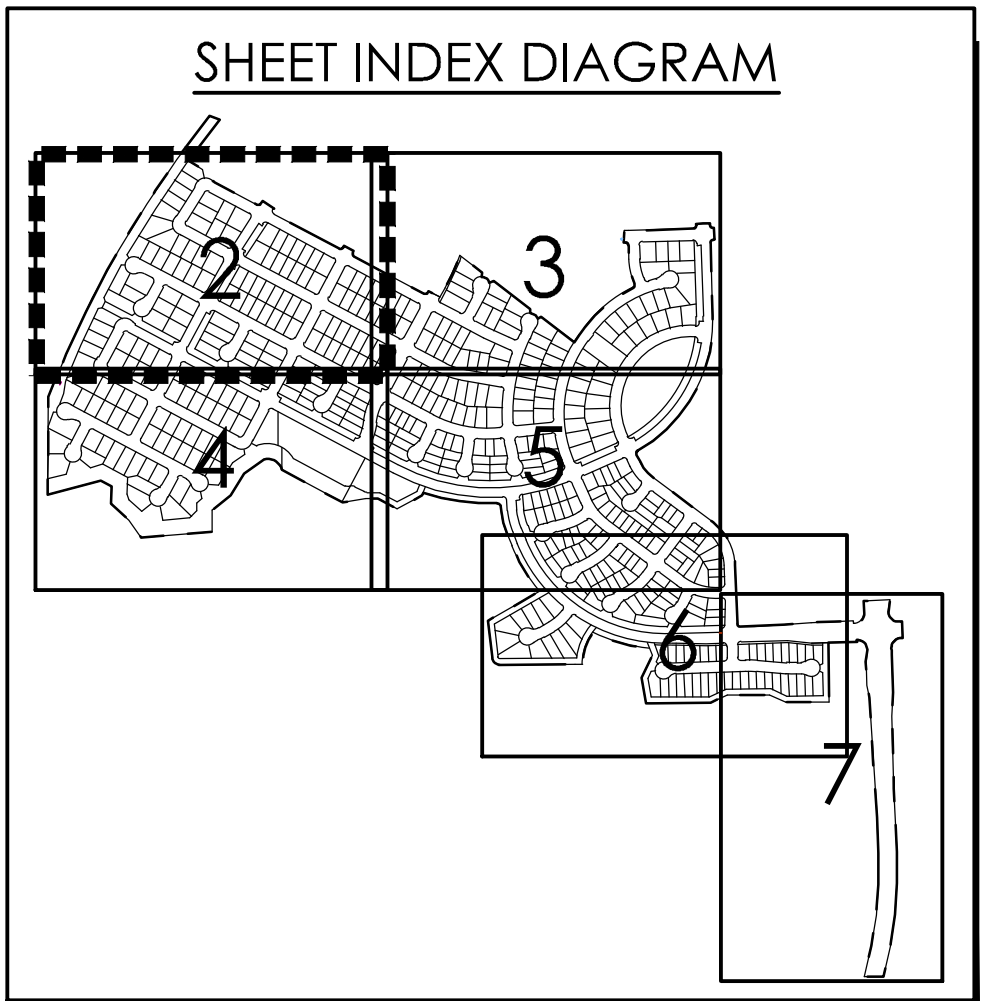

SEE SHEET 4

SEE SHEET 3

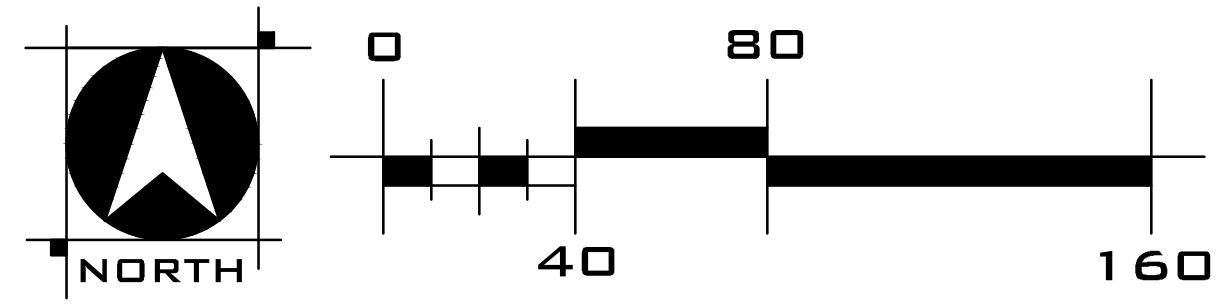

WOOD RODGERS
DEVELOPING INNOVATIVE DESIGN SOLUTIONS
3301 C St. Bldg. 100-B
Sacramento, CA 95816
Tel 916.341.7760
Fax 916.341.7767

LEGEND			
PROJECT BOUNDARY	PUE (TYP)	SEWER MAIN	DRAIN INLET
VILLAGE LOT LINE	VILLAGE BOUNDARY	SEWER MANHOLE	WATER MAIN
RIGHT-OF-WAY	TOP BACK OF CURB	DRAINAGE MAIN	GATE VALVE
STREET CENTERLINE	SIDEWALK	DRAINAGE MANHOLE	FIRE HYDRANT
PROPOSED LOTS	LIP OF CURB		

TENTATIVE SUBDIVISION MAP

AMORUSO RANCH

PHASE 1 - SUBPHASE A1

CITY OF ROSEVILLE, CALIFORNIA
FEBRUARY 14, 2022

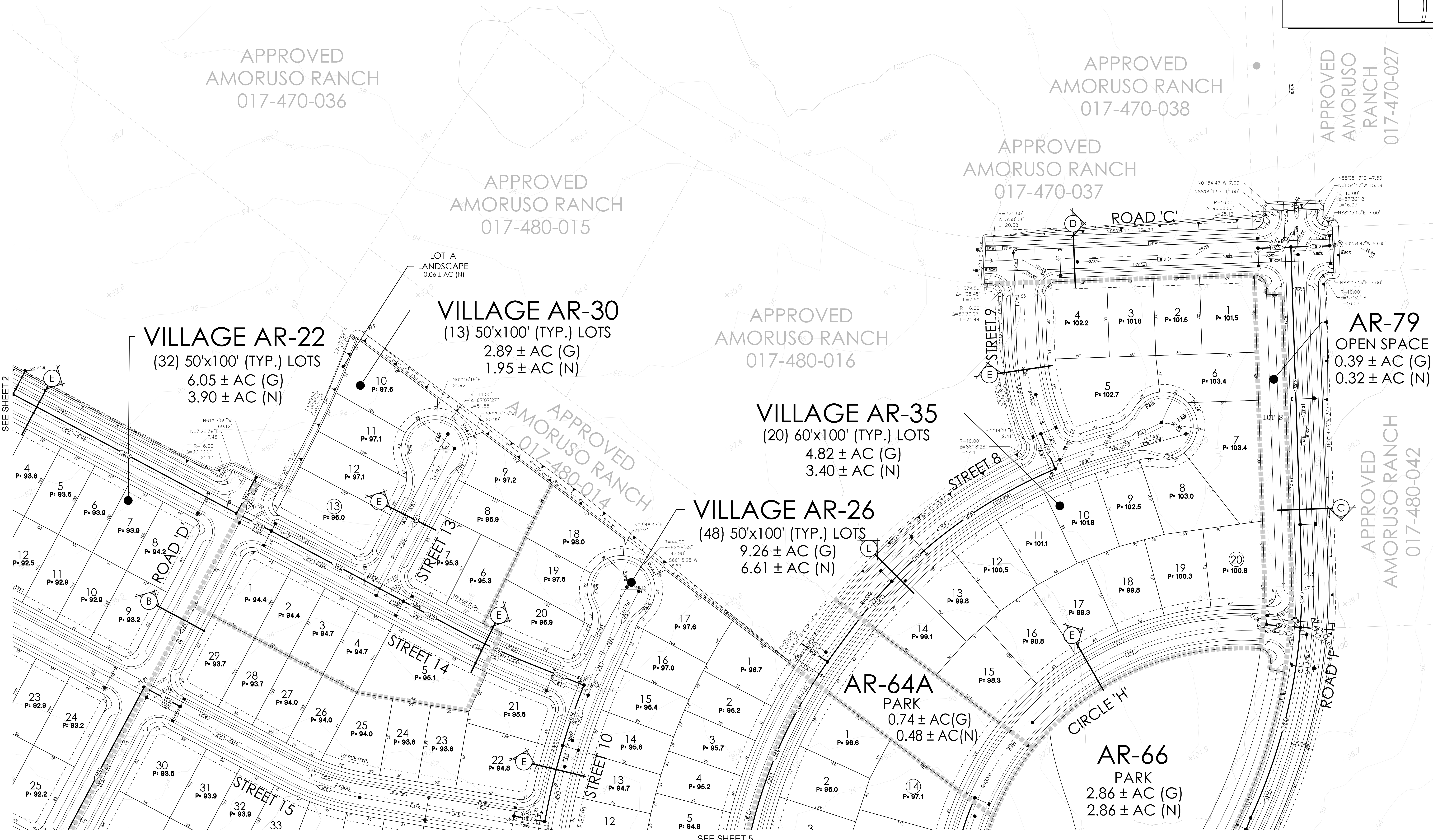
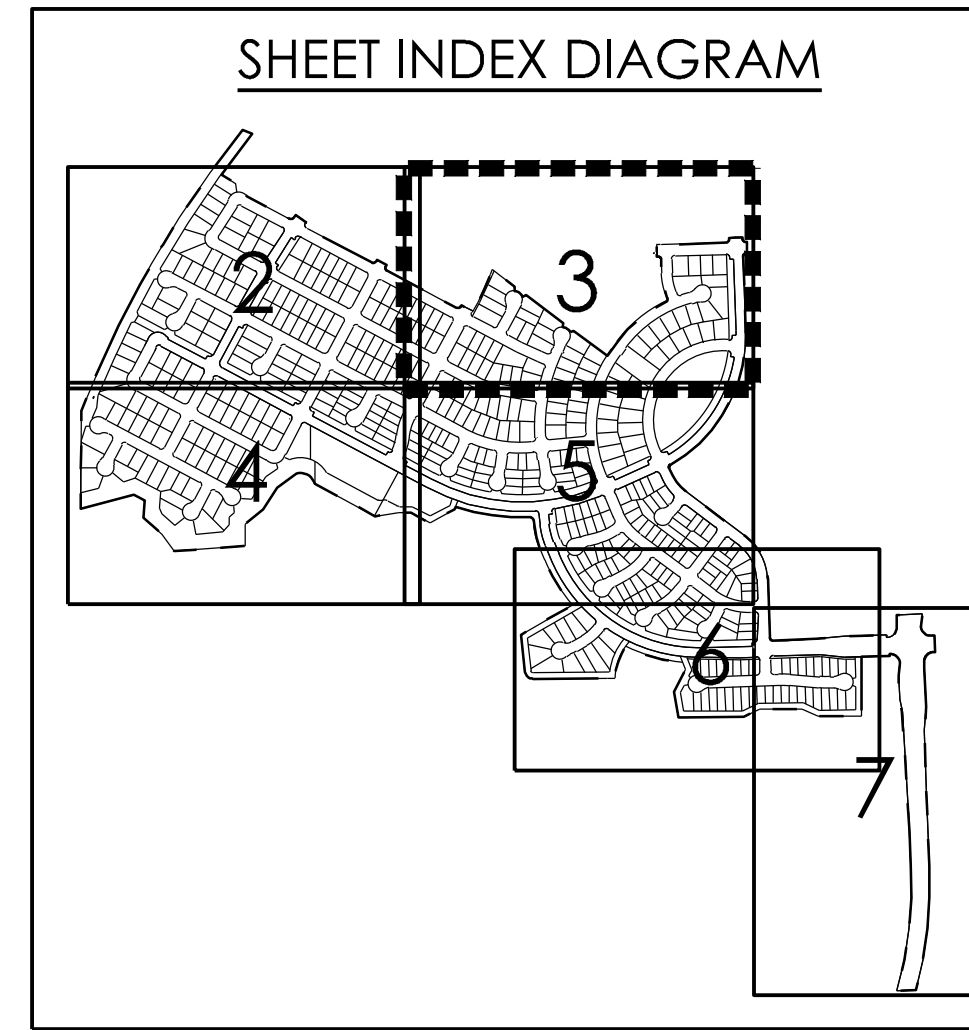

SEE SHEET 2

SEE SHEET 5

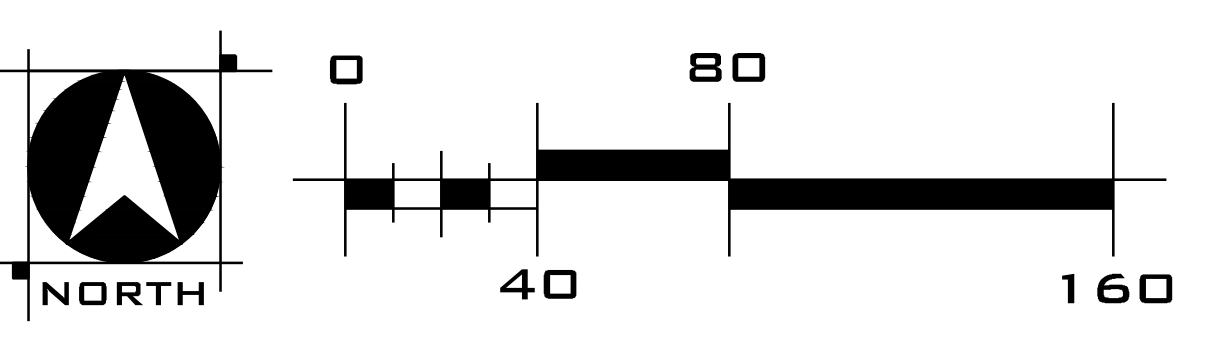

WOOD RODGERS
DEVELOPING INNOVATIVE DESIGN SOLUTIONS
3301 C St. Bldg. 100-B Tel 916.341.7760
Sacramento, CA 95816 Fax 916.341.7767

SHEET 3 OF 7
AMORUSO RANCH - PHASE A1 - TENTATIVE SUBDIVISION MAP

LEGEND			
PROJECT BOUNDARY	--- --	PUE (TYP)	---
VILLAGE LOT LINE	---	VILLAGE BOUNDARY	---
RIGHT-OF-WAY	---	TOP BACK OF CURB	---
STREET CENTERLINE	---	SIDEWALK	---
PROPOSED LOTS	---	LIP OF CURB	---
SEWER MAIN	---	SEWER MANHOLE	●
WATER MAIN	---	DRAINAGE MAIN	---
DRAIN INLET	---	DRAINAGE MANHOLE	●
GATE VALVE	---	FIRE HYDRANT	●

TENTATIVE SUBDIVISION MAP AMORUSO RANCH PHASE 1 - SUBPHASE A1

CITY OF ROSEVILLE, CALIFORNIA
FEBRUARY 14, 2022

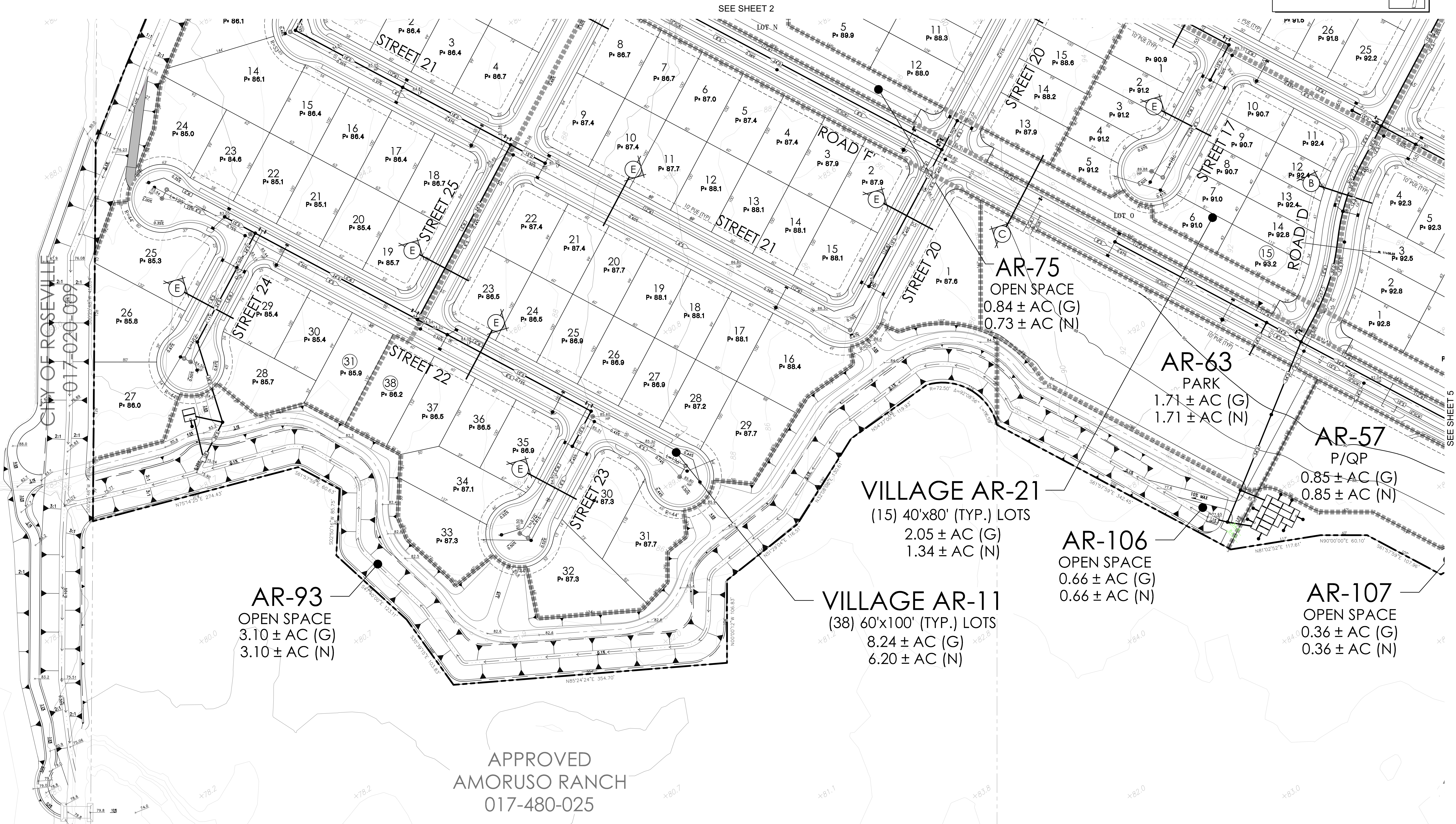
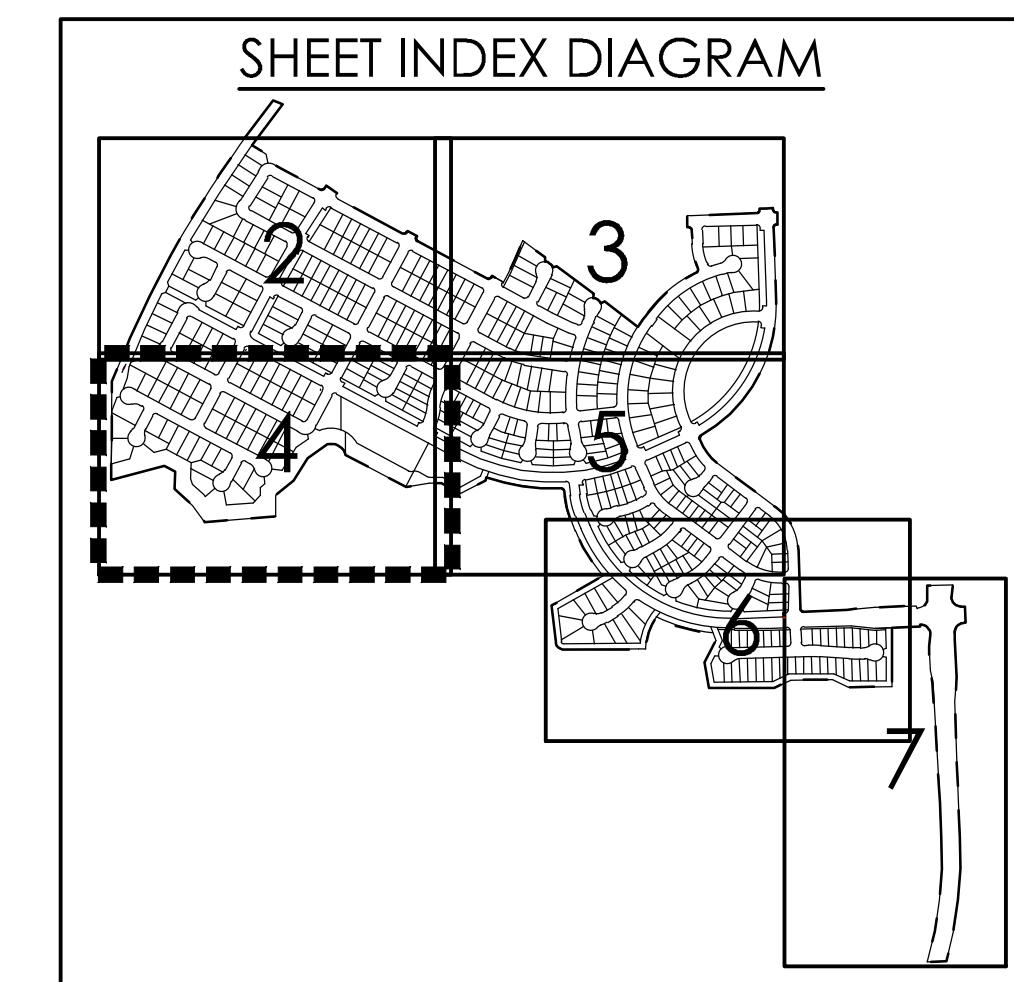

AR-93
OPEN SPACE
3.10 ± AC (G)
3.10 ± AC (N)

VILLAGE AR-11
(38) 60'x100' (TYP.) LOTS
8.24 ± AC (G)
6.20 ± AC (N)

VILLAGE AR-21
(15) 40'x80' (TYP.) LOTS
2.05 ± AC (G)
1.34 ± AC (N)

AR-75
OPEN SPACE
0.84 ± AC (G)
0.73 ± AC (N)

AR-63
PARK
1.71 ± AC (G)
1.71 ± AC (N)

AR-57
P/QP
0.85 ± AC (G)
0.85 ± AC (N)

AR-106
OPEN SPACE
0.66 ± AC (G)
0.66 ± AC (N)

AR-107
OPEN SPACE
0.36 ± AC (G)
0.36 ± AC (N)

APPROVED
AMORUSO RANCH
017-480-025

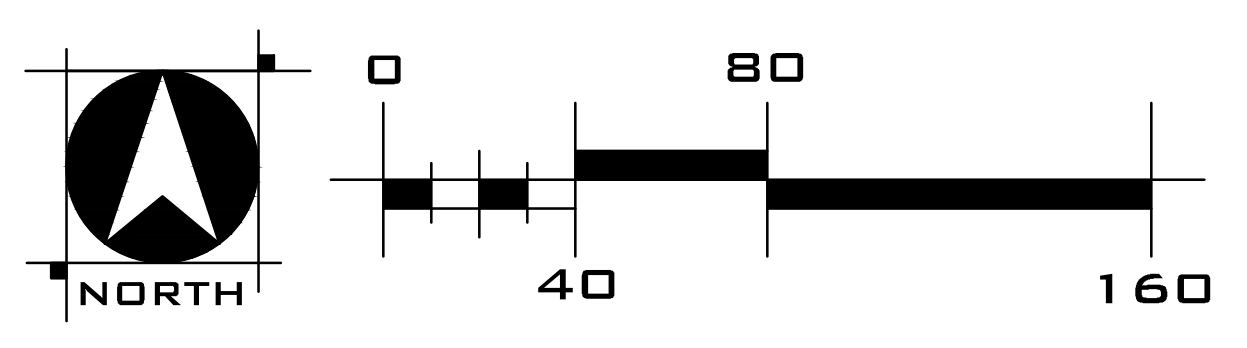

LEGEND			
PROJECT BOUNDARY	--- --	PUE (TYP)	---
VILLAGE LOT LINE	---	VILLAGE BOUNDARY	---
RIGHT-OF-WAY	---	TOP BACK OF CURB	---
STREET CENTERLINE	---	SIDEWALK	---
PROPOSED LOTS	---	LIP OF CURB	---
		SEWER MAIN	---
		SEWER MANHOLE	●
		DRAINAGE MAIN	---
		DRAINAGE MANHOLE	●
		DRAIN INLET	---
		WATER MAIN	---
		GATE VALVE	---
		FIRE HYDRANT	●

TENTATIVE SUBDIVISION MAP

AMORUSO RANCH

PHASE 1 - SUBPHASE A1

CITY OF ROSEVILLE, CALIFORNIA
FEBRUARY 14, 2022

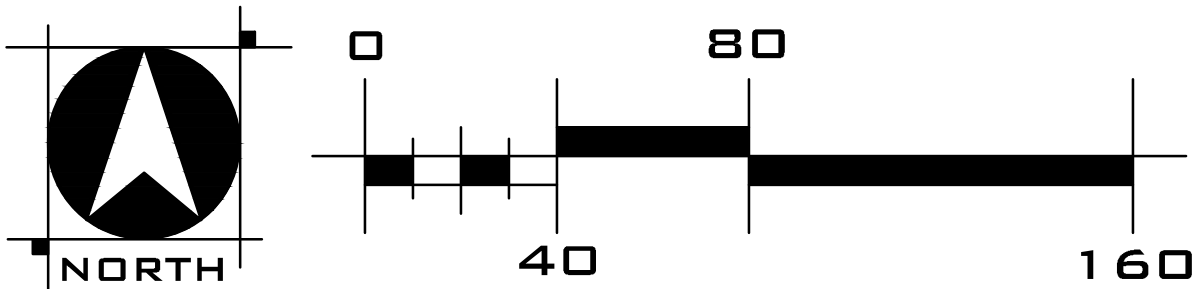
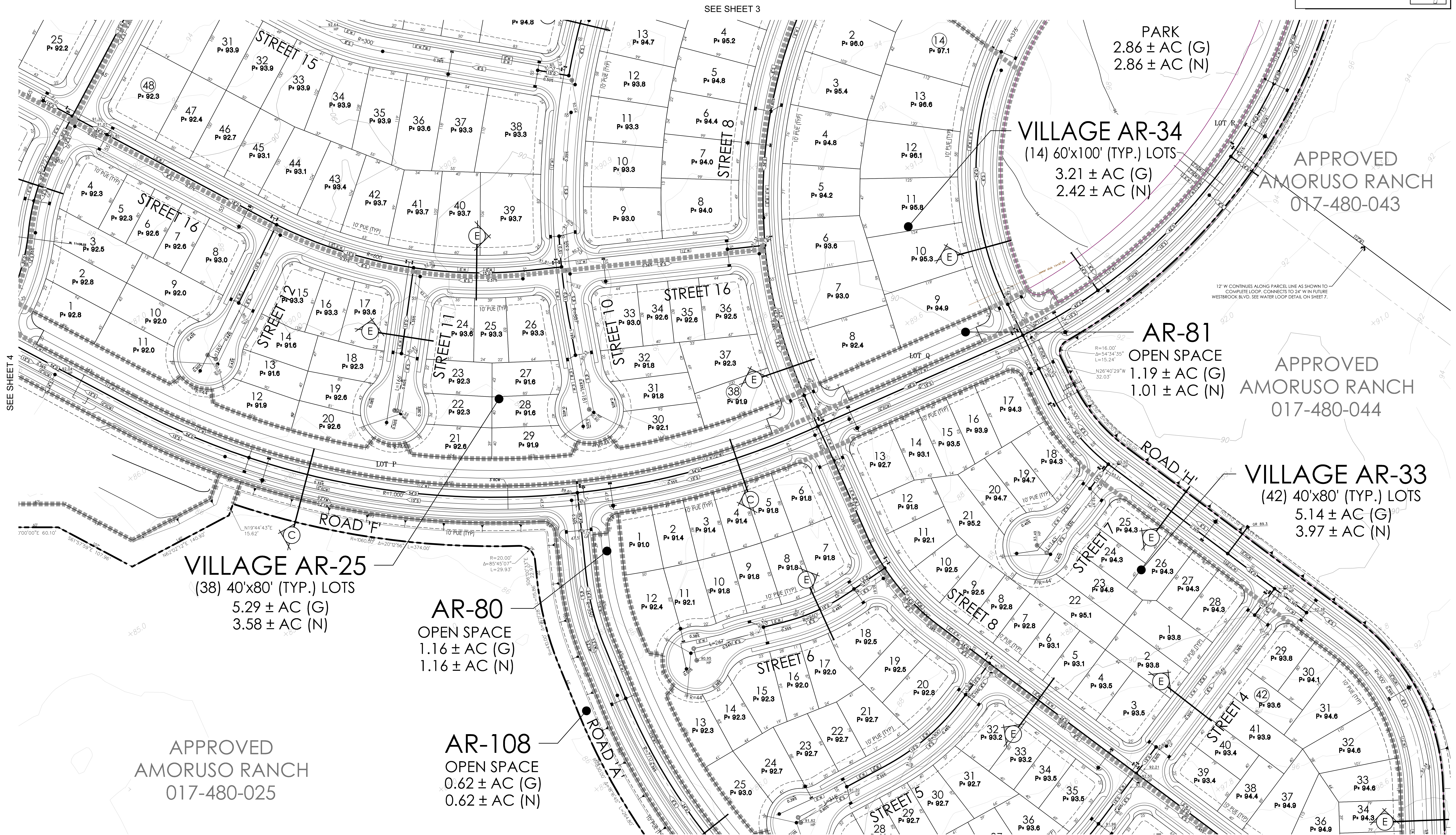
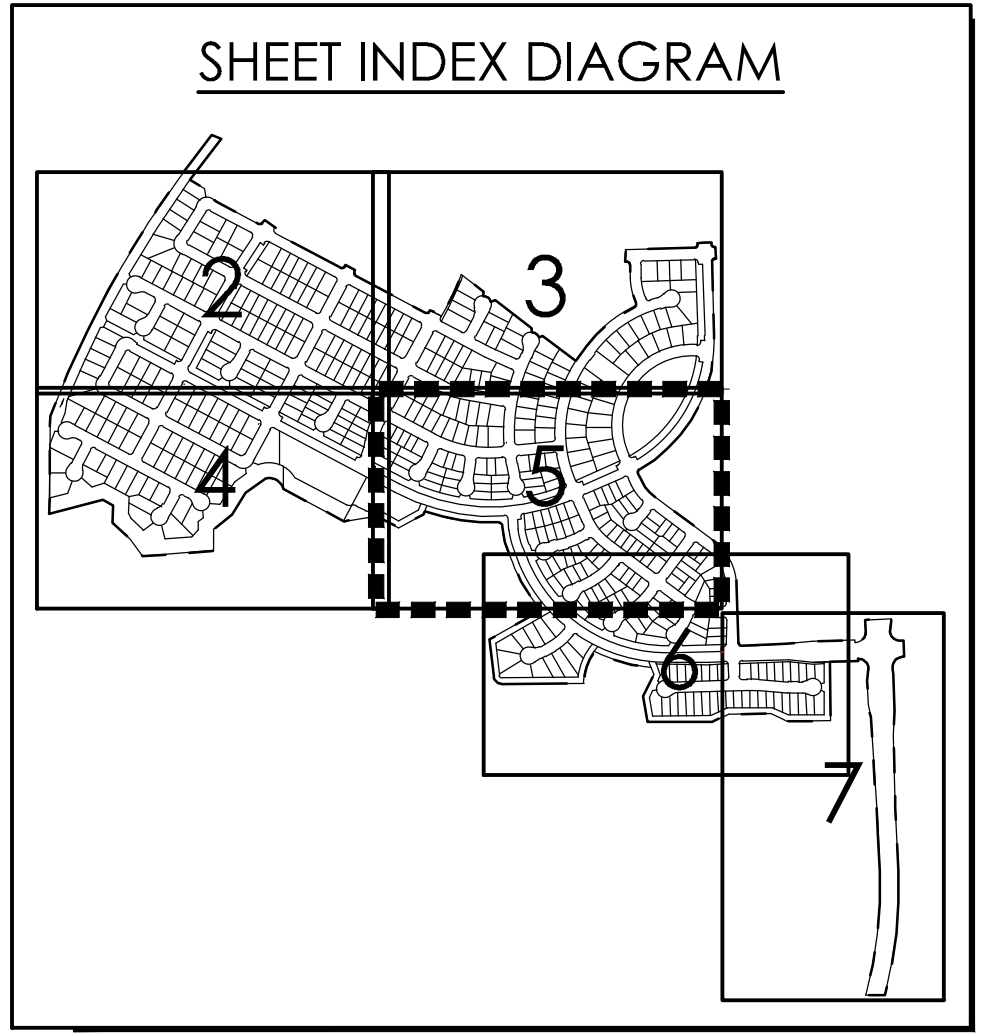

WOOD RODGERS
DEVELOPING INNOVATIVE DESIGN SOLUTIONS
3301 C St, Bldg. 100-B
Sacramento, CA 95816
Tel 916.341.7760
Fax 916.341.7767

LEGEND			
PROJECT BOUNDARY	--- --	PUE (TYP)	---
VILLAGE LOT LINE	---	VILLAGE BOUNDARY	---
RIGHT-OF-WAY	---	TOP BACK OF CURB	---
STREET CENTERLINE	---	SIDEWALK	---
PROPOSED LOTS	---	LIP OF CURB	---
SEWER MAIN	---	SEWER MANHOLE	●
DRAINAGE MAIN	---	DRAINAGE MANHOLE	●
DRAIN INLET	---	WATER MAIN	---
GATE VALVE	---	FIRE HYDRANT	●

TENTATIVE SUBDIVISION MAP AMORUSO RANCH PHASE 1 - SUBPHASE A1

CITY OF ROSEVILLE, CALIFORNIA
FEBRUARY 14, 2022

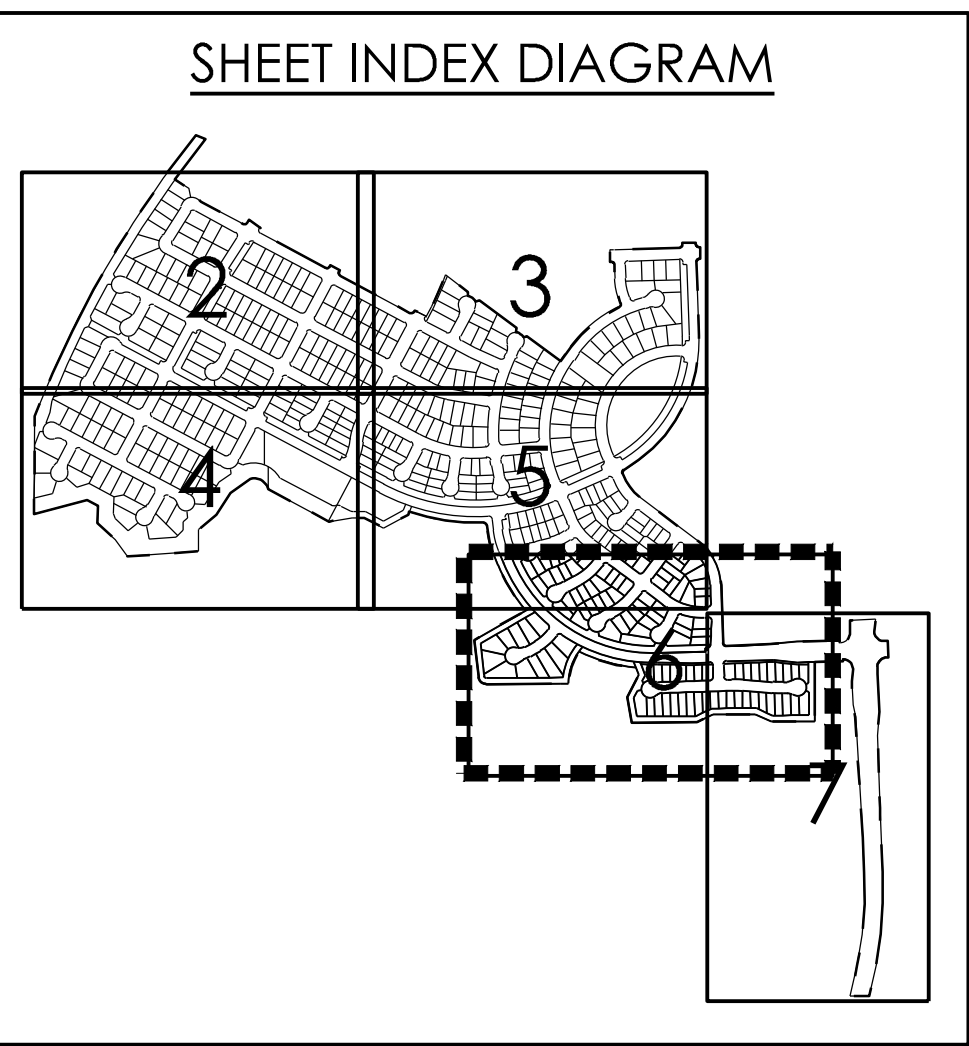

AR-108
OPEN SPACE
0.62 ± AC (G)
0.62 ± AC (N)

APPROVED
AMORUSO RANCH
017-480-044

VILLAGE AR-37
(39) 40'x80' (TYP.) LOTS
4.96 ± AC (G)
3.55 ± AC (N)

VILLAGE AR-24
(12) 50'x100' (TYP.) LOTS
2.50 ± AC (G)
2.10 ± AC (N)

AR-109
OPEN SPACE
0.77 ± AC (G)
0.77 ± AC (N)

VILLAGE AR-32
(58) 40'x80' (TYP.) LOTS
7.78 ± AC (G)
5.57 ± AC (N)

AR-111
OPEN SPACE
0.19 ± AC (G)
0.19 ± AC (N)

AR-112
OPEN SPACE
1.05 ± AC (G)
1.05 ± AC (N)

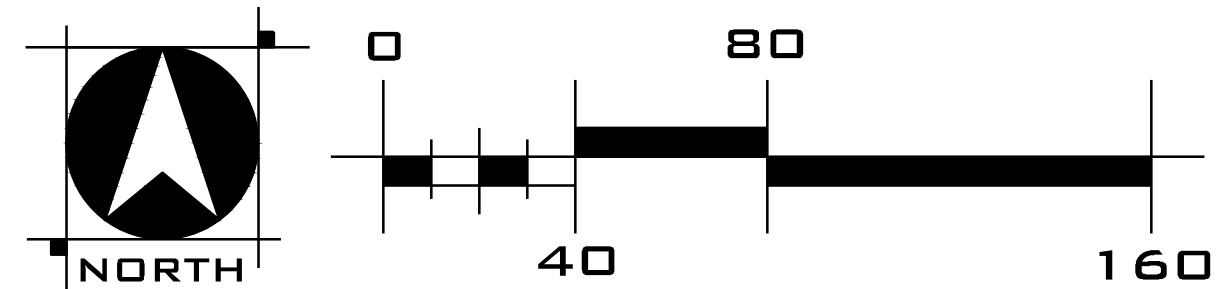
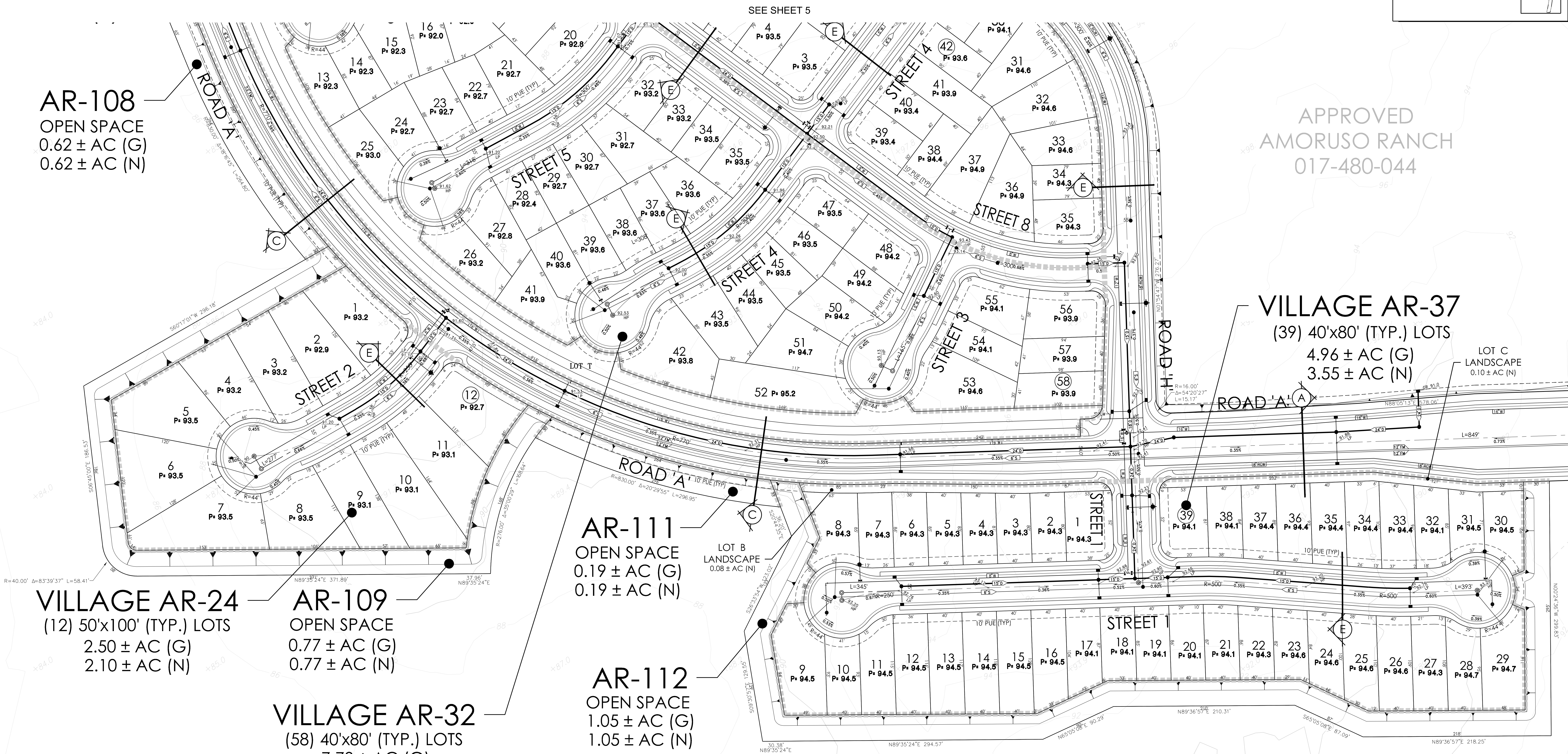

LEGEND			
PROJECT BOUNDARY	PUE (TYP)	SEWER MAIN	DRAIN INLET
VILLAGE LOT LINE	VILLAGE BOUNDARY	SEWER MANHOLE	WATER MAIN
RIGHT-OF-WAY	TOP BACK OF CURB	DRAINAGE MAIN	GATE VALVE
STREET CENTERLINE	SIDEWALK	DRAINAGE MANHOLE	FIRE HYDRANT
PROPOSED LOTS	LIP OF CURB		

TENTATIVE SUBDIVISION MAP

AMORUSO RANCH

PHASE 1 - SUBPHASE A1

CITY OF ROSEVILLE, CALIFORNIA
FEBRUARY 14, 2022

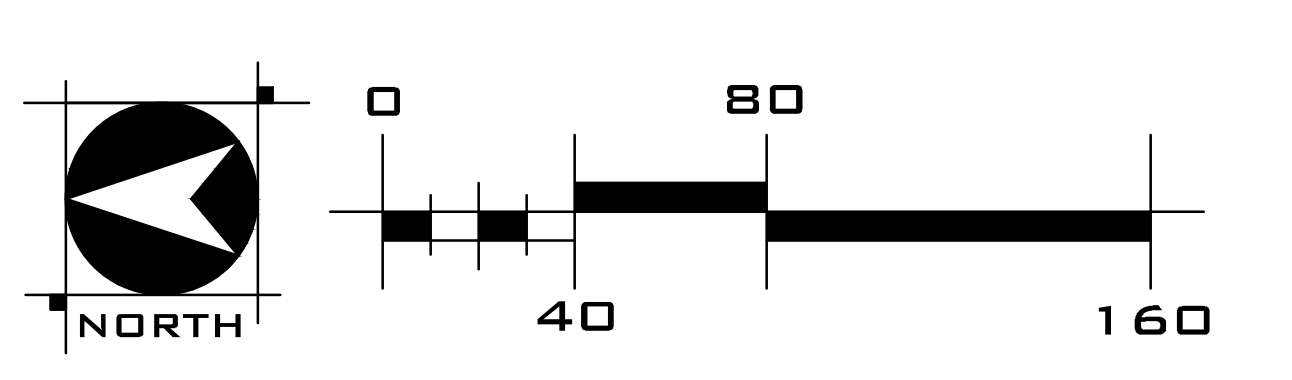
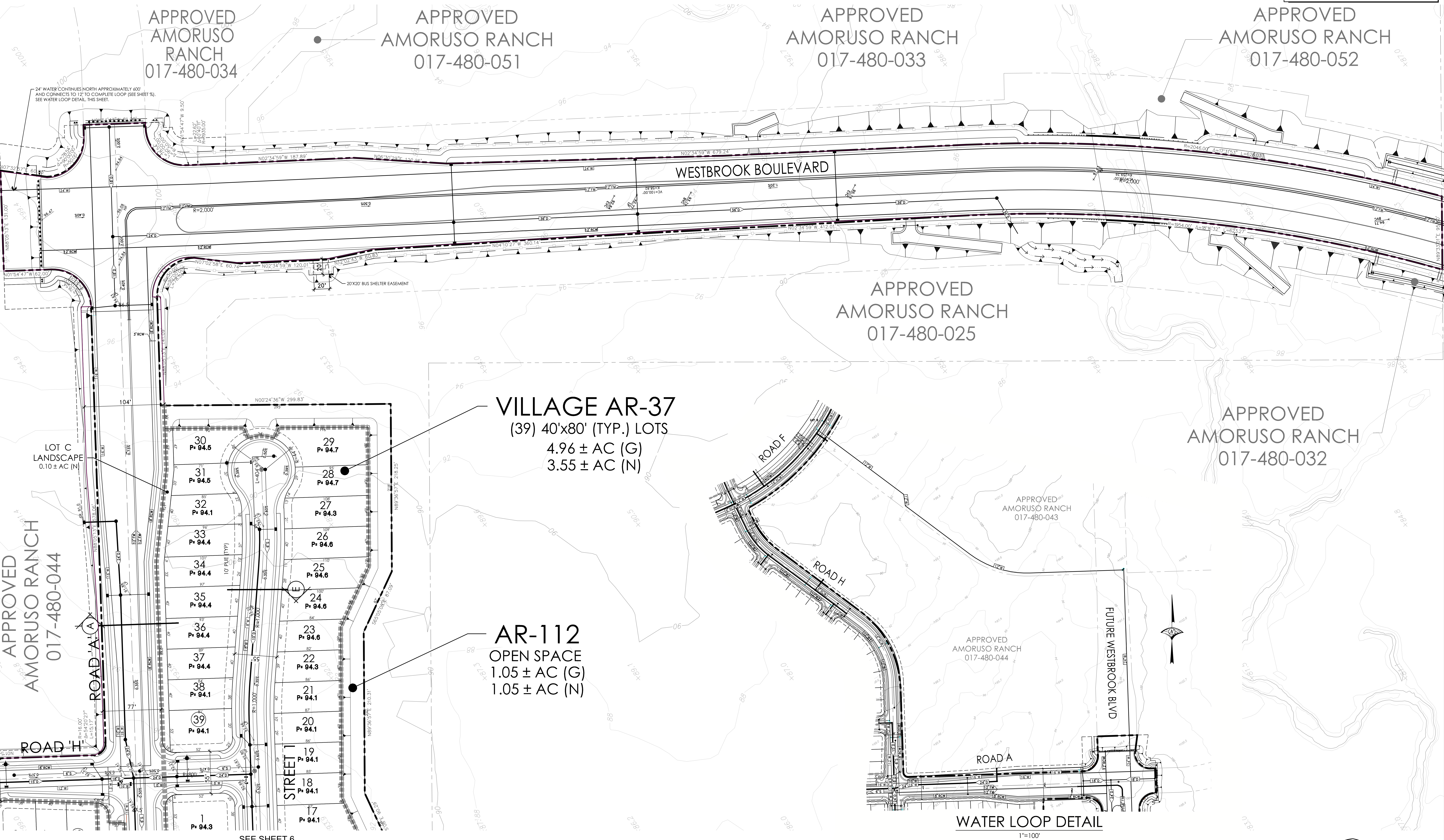
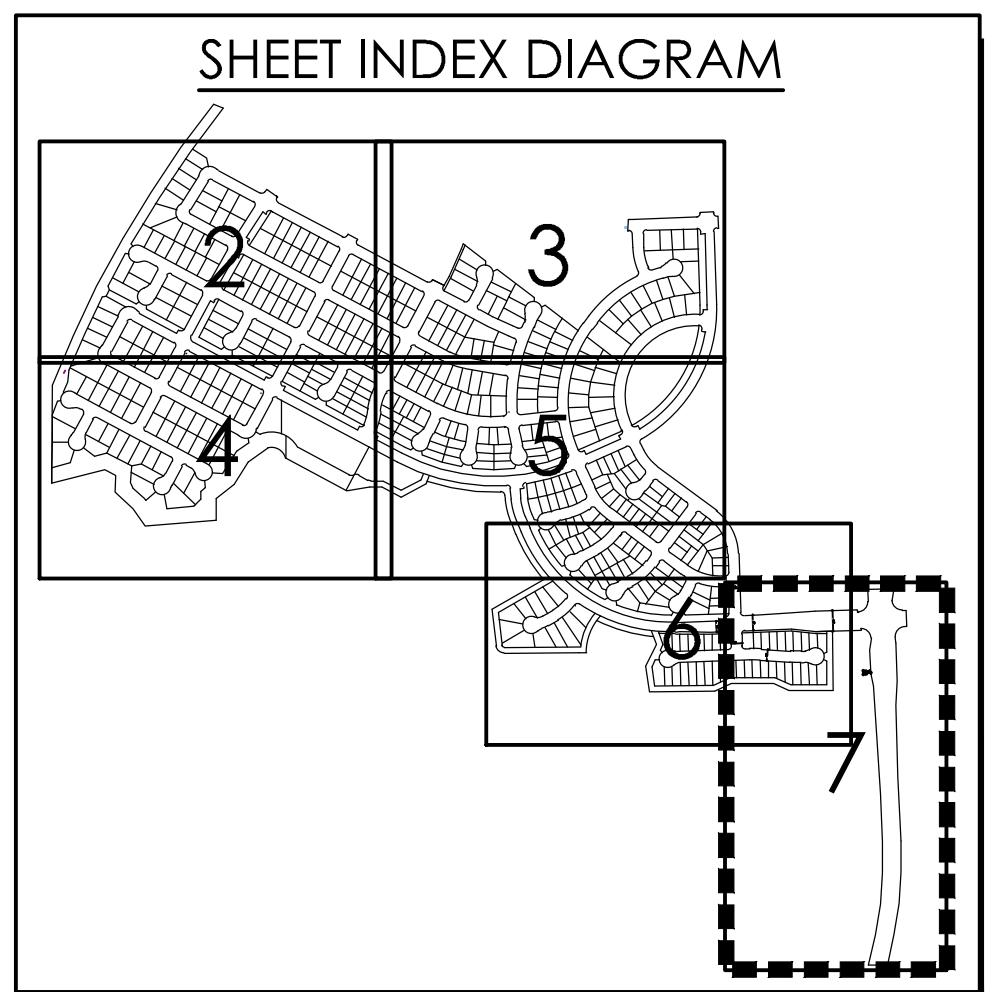

WATER LOOP DETAIL
1"=100'

WOOD RODGERS
DEVELOPING INNOVATIVE DESIGN SOLUTIONS
3301 C St. Bldg. 100-B
Sacramento, CA 95816
Tel 916.341.7760
Fax 916.341.7767
SHEET 7 OF 7